

REVISIONS			
REV	DESCRIPTION	DATE	APPROVED
E	REDRAWN - SUPERSEDES 1SA_FRA-SHEET 3 REV."D" FOR 1SA16FRA16 (1) WAS 14.8 REF	10-31-95	EN-F16050 DP-24900
F	1) NOTE #1(b) WAS ZINC PLATE PER ACES 2751	2020-06-18 ARK	CO-0204147

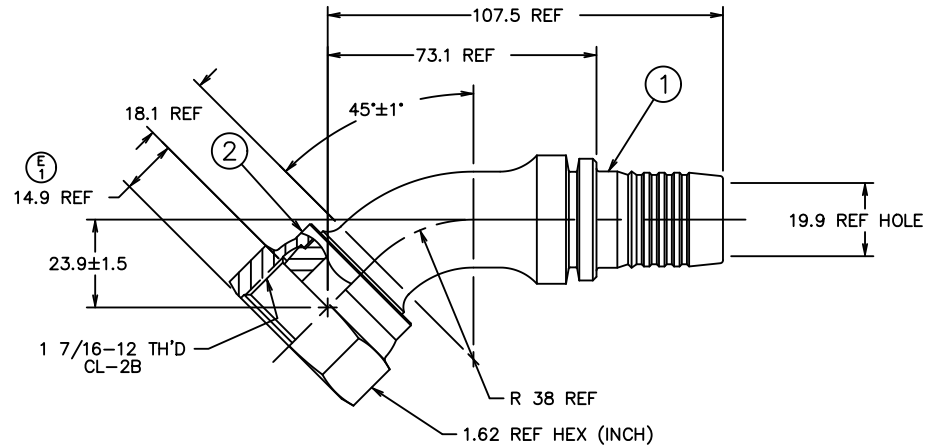

107.5	4.23
73.1	2.88
38	1.50
23.9±1.5	.94±.06
19.9	.78
18.1	.71
14.9	.59
MM	INCH

CONVERSION

METRIC

1SA16FRA16	1F40022-1616AB	FC1473-16S			
AEROQUIP PART NUMBER	① NIPPLE	② NUT			
LIST OF MATERIALS					
ITEM NO.	MATERIAL	DRAWN R.D. GARRETT	FLUID CONVEYANCE DIVISION DRAWING TITLE NIPPLE ASSEMBLY 45° ORS FEMALE SWIVEL 2781 HOSE		
1	STEEL	CHECKED M. MOLINA			
2	STEEL	APPROVED R.D. GARRETT			
		RELEASE DATE 1995-11-01			
		EN-F16050	SIZE A2	DRAWING NUMBER 1SA16FRA16	REV F
		DP-24900	SCALE 1/1	DIST U	CAGE CODE 01276
		THIRD ANGLE PROJECTION	SHEET 1		
THE REPRODUCTION, DISTRIBUTION AND UTILIZATION OF THIS DOCUMENT AS WELL AS THE COMMUNICATION OF ITS CONTENTS TO OTHERS WITHOUT EXPLICIT AUTHORIZATION IS PROHIBITED. OFFENDERS WILL BE HELD LIABLE FOR THE PAYMENT OF DAMAGES. ALL RIGHT RESERVED IN THE EVENT OF THE GRANT OF A PATENT, UTILITY MODEL OR DESIGN. (PER ISO 18016)					

1. PROCESS AS FOLLOWS:
 (a) BEND NIPPLE TO DIMENSIONS SHOWN.
 (b) ZINC PLATE PER ES 2751DB.
 (c) CRIMP NUT PER ACES 2409P1. F1