

REV	DESCRIPTION	BY	CHK	DATE	ECN / MPS
A	ENGINEERING RELEASE	RSI	JGS	2/12/05	M63978

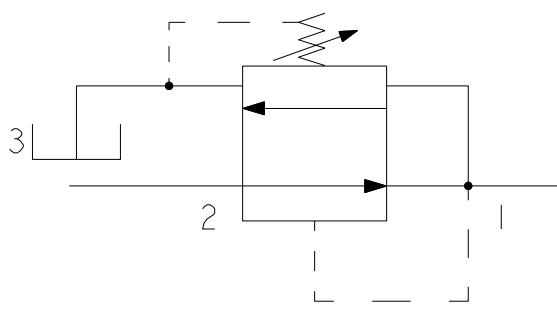
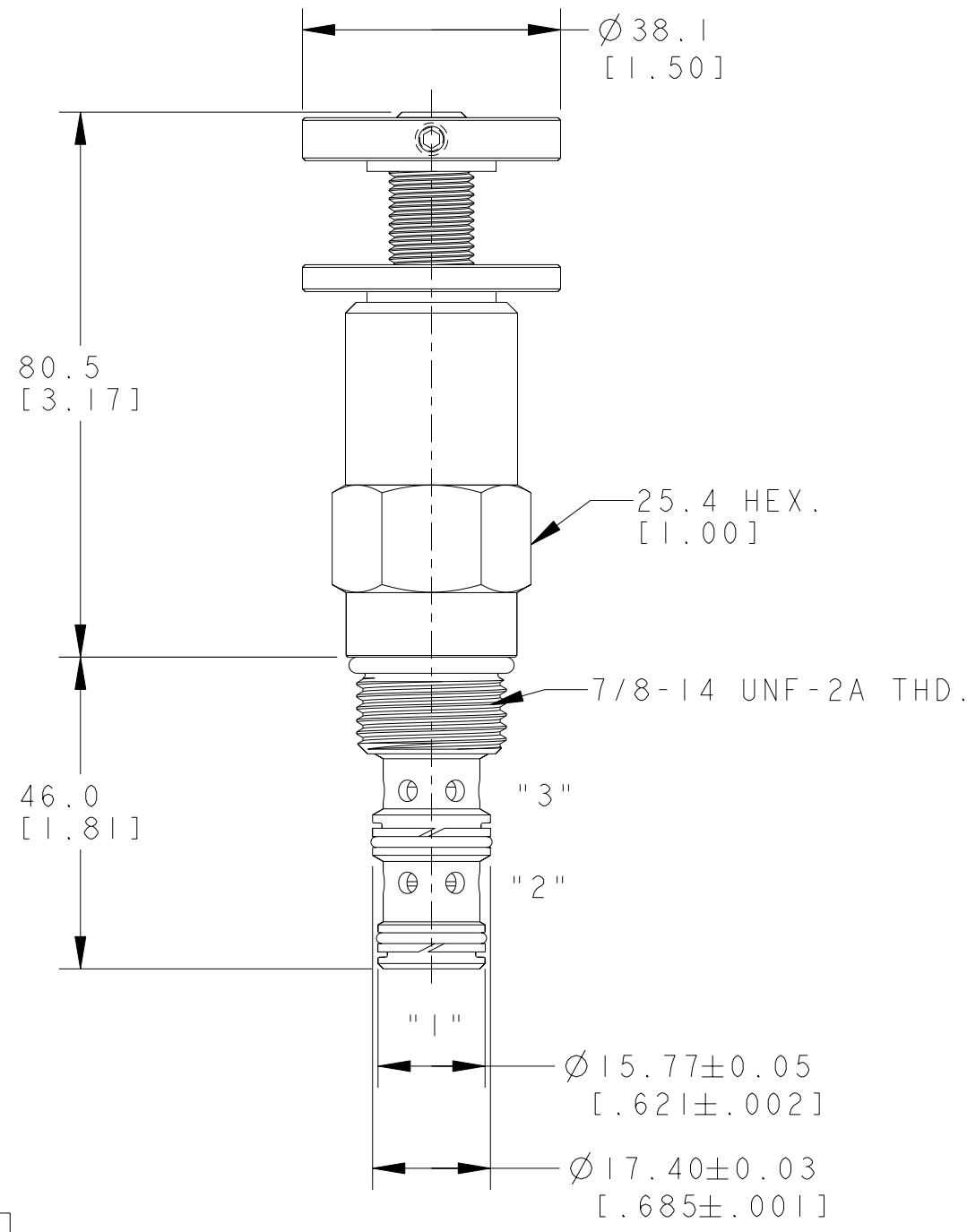

NOTE:  
 1. USE VALVE CAVITY C-10-3.  
 2. NET WEIGHT OF CARTRIDGE: 0.24kg [.54 lb]  
 3. TORQUE INTO CAVITY:  
 ALUMINIUM CAVITY: 47-54 N.m [35-40 lbf.ft]  
 STEEL CAVITY : 68-75 N.m [50-55 lbf.ft]

MC  
 DISTRIBUTION CODE(S)

UNLESS OTHERWISE SPECIFIED ALL DIMENSIONS ARE IN INCHES <input type="checkbox"/> MILLIMETERS (INCHES) <input checked="" type="checkbox"/>	DRAWING BASED ON ANSI Y14.5M-1982	
	NOTICE TO PERSONS RECEIVING THIS DRAWING AND / OR TECHNICAL INFORMATION	
TOLERANCES .X ± -- .XX ± -- .XXX ± -- ∠ ± --	Eaton Corporation claims proprietary rights in the information disclosed hereon. This document is issued in confidence and is not to be reproduced or used to manufacture anything shown hereon without the written permission of the Eaton Corporation.	
	DRAWN SKS BY/DATE 05/17/05	MATERIAL/HEAT TREAT -- --
UNSPECIFIED RADII ARE: --	CHECKED RSI BY/DATE 05/18/05	Eaton Hydraulics, Inc. 14615 Lone Oak Road Eden Prairie, Mn. 55344
	ENGRG -- BY/DATE --	
UNSPECIFIED DRAFT ANGLES ARE: --°	METALLURGY -- BY/DATE --	NUMBER A-2682-029
	THIRD ANGLE PROJECTION	
B SIZE	DO NOT SCALE	SHEET 1 OF 1

