

REV	DESCRIPTION	BY	CHK	DATE	ECN / MPS
A	ENGINEERING RELEASE	NJH	NJH	08-21-08	0021240
B	REVISED	NJH	NJH	11-16-09	0021096-ECR

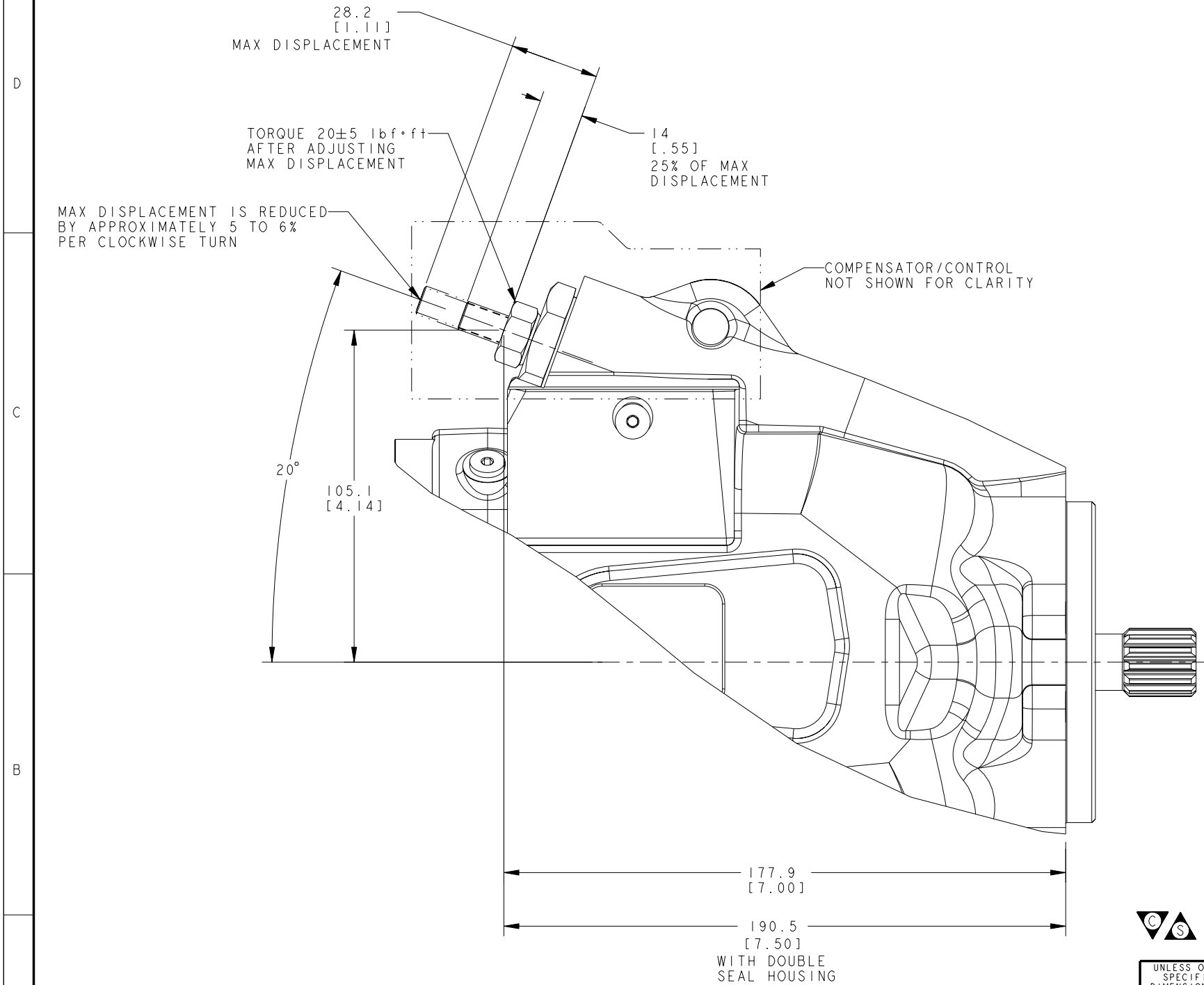

REVIEWED FOR CLASSIFICATION PER ESP-042

DISTRIBUTION CODE(S)

UNLESS OTHERWISE SPECIFIED ALL DIMENSIONS ARE IN INCHES <input type="checkbox"/> MILLIMETERS (INCHES) <input checked="" type="checkbox"/> TOLERANCES .X ± ---- .XX ± REF .XXX ± ONLY < ± ---- UNSPECIFIED RADII ARE: ---- UNSPECIFIED DRAFT ANGLES ARE: ---- C SIZE	DRAWING BASED ON ANSI Y14.5M-1982		
	THE REPRODUCTION, DISTRIBUTION, AND UTILIZATION OF THIS DOCUMENT, AS WELL AS THE COMMUNICATION OF ITS CONTENTS TO OTHERS WITHOUT EXPLICIT AUTHORIZATION IS PROHIBITED. OFFENDERS WILL BE HELD LIABLE FOR THE PAYMENT OF DAMAGES. ALL RIGHTS RESERVED IN THE EVENT OF THE GRANT OF A PATENT, UTILITY MODEL, OR DESIGN. (PER ISO 16016)		
	DRAWN NJH BY/DATE 8-21-08 CHECKED NJH BY/DATE 8-21-08	MATERIAL/HEAT TREAT \	
	ENGRG DJZ BY/DATE 8-21-08 METALLURGY ---- BY/DATE ----	TITLE EXT. MANUAL STROKE ADJ. INSTALL	
THIRD ANGLE PROJECTION DO NOT SCALE	MICROINCHES <input type="checkbox"/> MICROMETERS (MICROINCHES) <input checked="" type="checkbox"/> ARITHMETICAL AVERAGE <input checked="" type="checkbox"/>	NUMBER A-3306-001 SCALE 1/1 SHEET 1 OF 1	

