

REVISIONS			
REV	DESCRIPTION	DATE	APPROVED
A	1) ADDED NEW PART NO. "FCE4432"	2020-08-24 AAG	CO-0207135
B	1) FBE4432 WAS FCE4432.	2020-09-29 AAG	CO-0208943

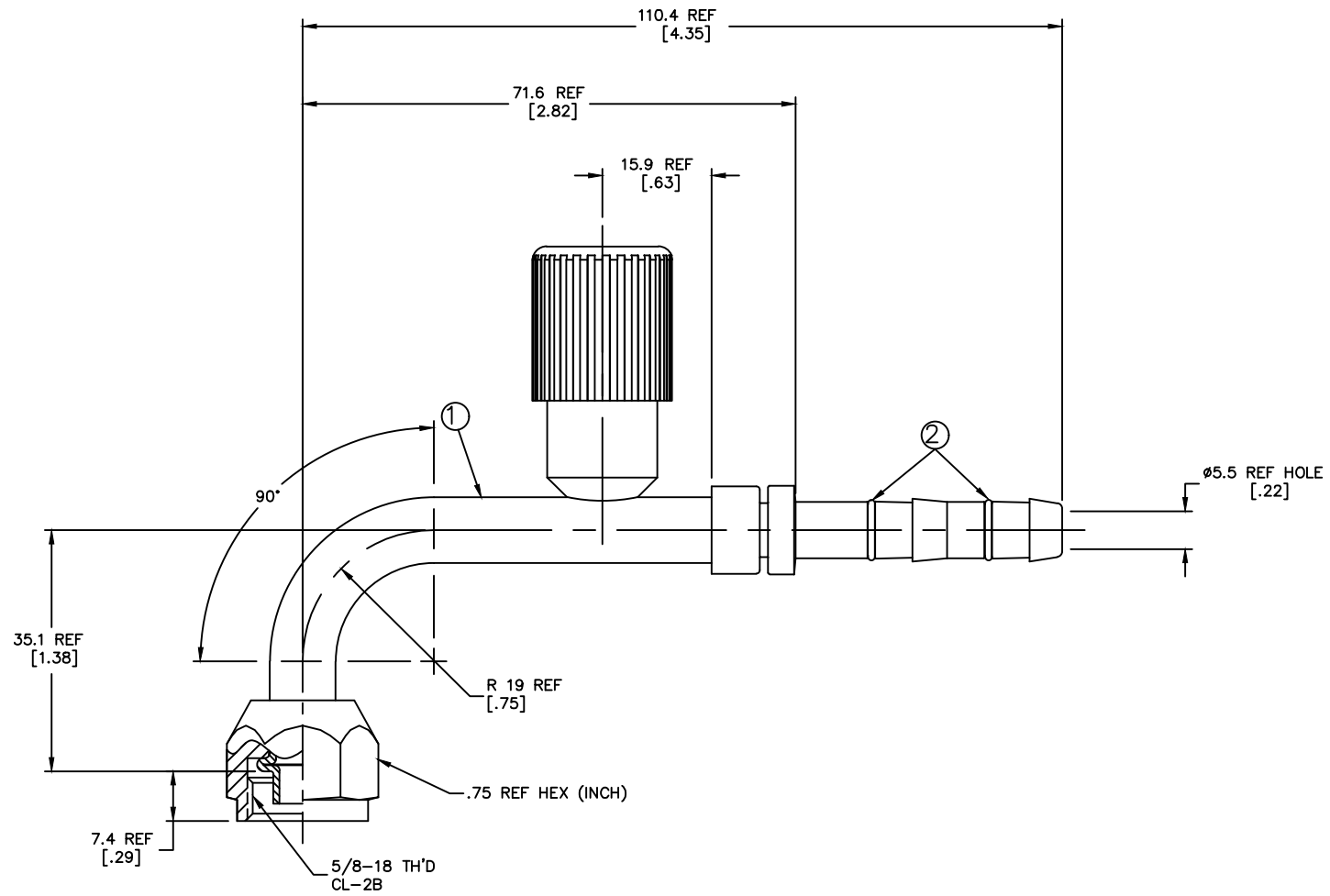

METRIC

- DIMENSIONS ARE IN MILLIMETERS [INCHES].
- LUBRICATE O'RINGS AND ASSEMBLE TO NIPPLE AS SHOWN.

A		B	
FBE4432	FJ3013-02-0606S	FJ2013-02-0606S	1F40106-06
HIGH PERFORMANCE PART NUMBER	PART NUMBER	① NIPPLE ASSEMBLY	② O'RING (2 REQ'D)
LIST OF MATERIALS			
ITEM NO.	MATERIAL	DRAWN W.R.HYDE CHECKED R.D.GARRETT APPROVED R.D.GARRETT RELEASE DATE 1999-12-19 EN-F19520 DP-1256 THIRD ANGLE PROJECTION	
1	STEEL	FLUID CONVEYANCE DIVISION DRAWING TITLE <b>FITTING ASSEMBLY</b> 90°, SAE FEMALE O'RING PILOT (SHORT) WITH HIGH SIDE CHARGE PORT, GH134 HOSE	
2	HNBR		
		SIZE A2	DRAWING NUMBER FJ3013-02-0606S
		SCALE 2/1	REV B
		DIST U	SHEET 1
		CAGE CODE 01276	
<small>THE REPRODUCTION, DISTRIBUTION AND UTILIZATION OF THIS DOCUMENT, AS WELL AS THE COMMUNICATION OF ITS CONTENTS TO OTHERS WITHOUT EXPLICIT AUTHORIZATION IS PROHIBITED. OFFENDERS WILL BE HELD LIABLE FOR THE PAYMENT OF DAMAGES. ALL RIGHTS RESERVED IN THE EVENT OF THE GRANT OF A PATENT, UTILITY MODEL OR DESIGN. (PER ISO 18016)</small>			