

THE REPRODUCTION, DISTRIBUTION AND UTILIZATION OF THIS DOCUMENT AS WELL AS THE COMMUNICATION OF ITS CONTENTS TO OTHERS WITHOUT EXPLICIT AUTHORIZATION IS PROHIBITED. OFFENDERS WILL BE HELD LIABLE FOR THE PAYMENT OF DAMAGES. ALL RIGHT RESERVED IN THE EVENT OF THE GRANT OF A PATENT, UTILITY MODEL OR DESIGN. (PER ISO 10000)

| REVISIONS | | | |
|-----------|-------------|------|----------|
| REV | DESCRIPTION | DATE | APPROVED |
| | | | |

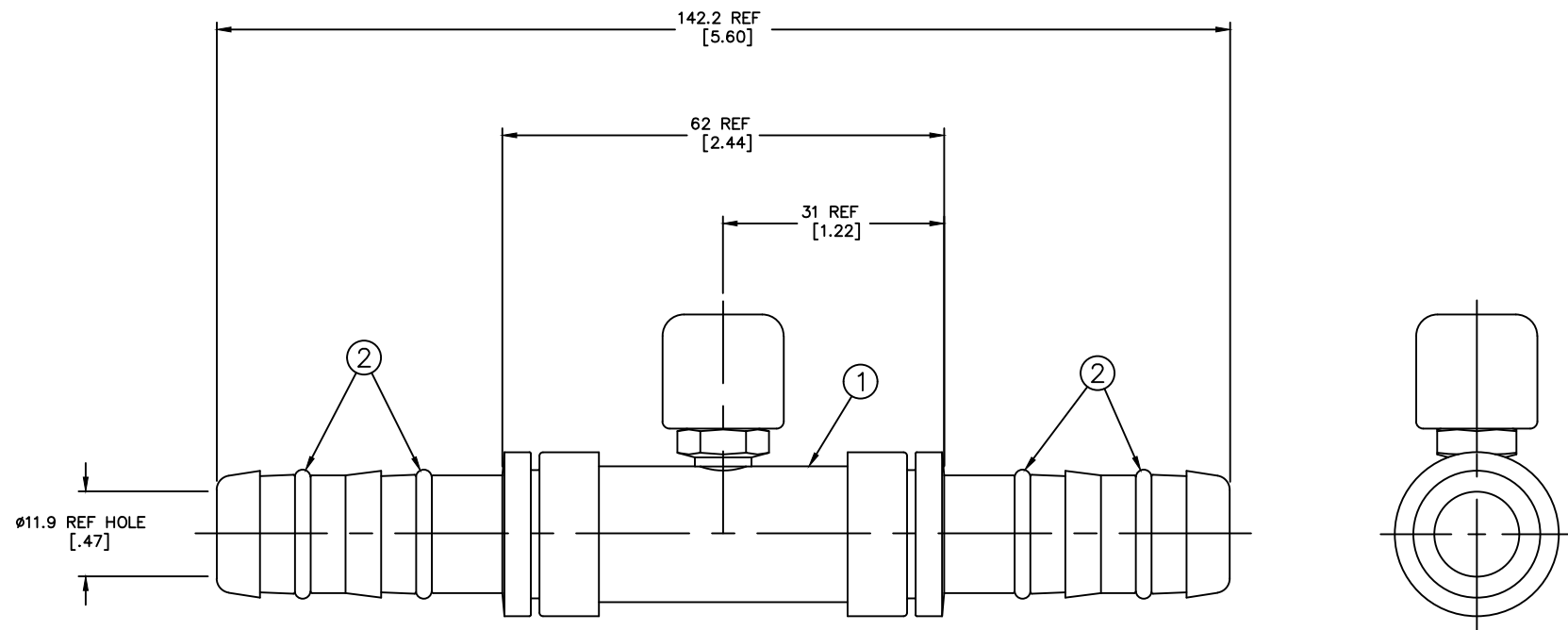

METRIC

- 2. DIMENSIONS ARE IN MILLIMETERS [INCHES].
- 1. PROCESS AS FOLLOWS:
 - (a) LUBRICATE O'RINGS AND ASSEMBLE ON NIPPLES AS SHOWN.

| FJ3171-1212S | FJ2171-1212S | 1F40106-12 | | |
|----------------------|-------------------|-------------------------|---------------------------|------------------------------|
| AEROQUIP PART NUMBER | ① NIPPLE ASSEMBLY | ② O'RING (4 REQ'D) | | |
| LIST OF MATERIALS | | | | |
| ITEM NO. | MATERIAL | DRAWN | FLUID CONVEYANCE DIVISION | |
| 1 | STEEL | R. KELLY | | |
| 2 | HNBR | CHECKED R. D. WEBB | | |
| | | APPROVED R.D.GARRETT | | |
| | | RELEASE DATE 2000-07-24 | | |
| | | EN-F20160 DP-1256 | | |
| | | THIRD ANGLE PROJECTION | SIZE A2 | DRAWING NUMBER FJ3171-1212S |
| | | ITEM TYPED TZA | SCALE 2/1 | DIST U CAGE CODE 01276 SHEET |

DWG. NO. FJ3171-1212S SH. REV.